



US Patent pending

Important: Before purchasing, contact InnoTek regarding inverter compatibility

INSTALLATION MANUAL

InnoTek Air HumidiFlex System

INTRODUCTION

- **Safety**

- ✓ **Must be installed by a qualified H.V.A.C technician.**
- ✓ **24-volt power must be off while wiring the controller.**
- ✓ **The unit must be reset after setting up parameters by pressing mode off**
- ✓ **At the bottom left of the display, the letters RD must be black to make any changes; this usually takes 2 minutes when booting up**

- **Content**

- 1) Equipment List and Description
- 2) Installation Details
- 3) System Configuration
- 4) Schematic
- 5) User (GUI) Graphical User Interface Display
- 6) Installer GUI
- 7) Connecting to Wi-Fi
- 8) How to connect the APP

- **Appendix**

A. Sensor 10 Kohm

1 19 Vesna

Bowmanville On.
Canada
L1C 0C7

2981 Ford ST.

Ogdensburg, New York
USA
13669



- B. Performance Capabilities
- C. Size Selection and Specification Details

EQUIPMENT (3 MAIN COMPONENTS)

- A. Dehumidification Mixed Air Controller (DMAC)
- B. BYPASS modulation frequency drive inline FAN
- C. Optional BYPASS damper

A. Dehumidification Mixed Air Controller (DMAC)

The DMAC is the main controller that connects all sensors, dampers, fan control, and equipment installed on any appropriate wall that the user has easy access to.

The DMAC is comprised of:

The DMAC includes the following sensors:

- **Indoor Temperature/Humidity Sensor (AH20):** Install near the existing indoor thermostat or sensor (if applicable).
- **Suction Line 10k Ohm Sensor:** Install as close as possible to the evaporator coil expansion valve bulb. If installed horizontally, follow the same installation guidelines as the bulb. Tie wraps and wrap-around insulation are included. See Appendix 1 for the sensor table.
- **Intake Air 10k Ohm Duct Sensor:** Install in the air duct of the indoor evaporator coil.
- **Delivery Air 10k Ohm Duct Sensor:** Install in the delivery air duct.

DMAC Controller Features:

- **Intuitive Control:** A user-friendly graphical interface (GUI) allows

selection from three pre-configured application models.

- **Flexible Dehumidification Control:** Choose between relative humidity (RH) or dew point control.
- **Precise Sensor Calibration:** All sensors are calibratable for optimal performance.
- **System Compatibility:** Works with a variety of HVAC systems, including heat pumps, single-stage, dual-stage, and inverter condensers.
- **Auxiliary Heat Support:** Integrates with auxiliary heat systems.
- **Humidifier Support:** Controls and integrations with humidifiers.

Key Benefit: The DMAC empowers installers to maximize dehumidification performance, achieving the best possible results for any installation.

2 19 Vesna
Bowmanville On.
Canada
L1C 0C7

2981 Ford ST.
Ogdensburg, New York
USA
13669



The controller offers to connect through Wi-Fi or an APP

The Installer GUI enables the installer to configure several parameters.

SETTING
SENSOR CALIBRATION
CONFIGURATION
TIMING

B.

Bypass Modulation Frequency Drive

Inline Both the bypass fan and optional damper are available in 8", 10", and 12" sizes to accommodate various condenser sizes (see Appendix 2 for sizing).

- The 110V fan includes a 6-foot power cord.
- The fan has a control junction box that the installer must wire to the DMAC.

C. Optional BYPASS damper

Bypass dampers are available in 3 sizes: 8,10, and 12 inches in diameter, and must match the Bypass Modulating Fan size.

It comes with a 24-volt actuator, normally closed, and spring return.

Several installation options for the bypass fan and optional damper are illustrated below.

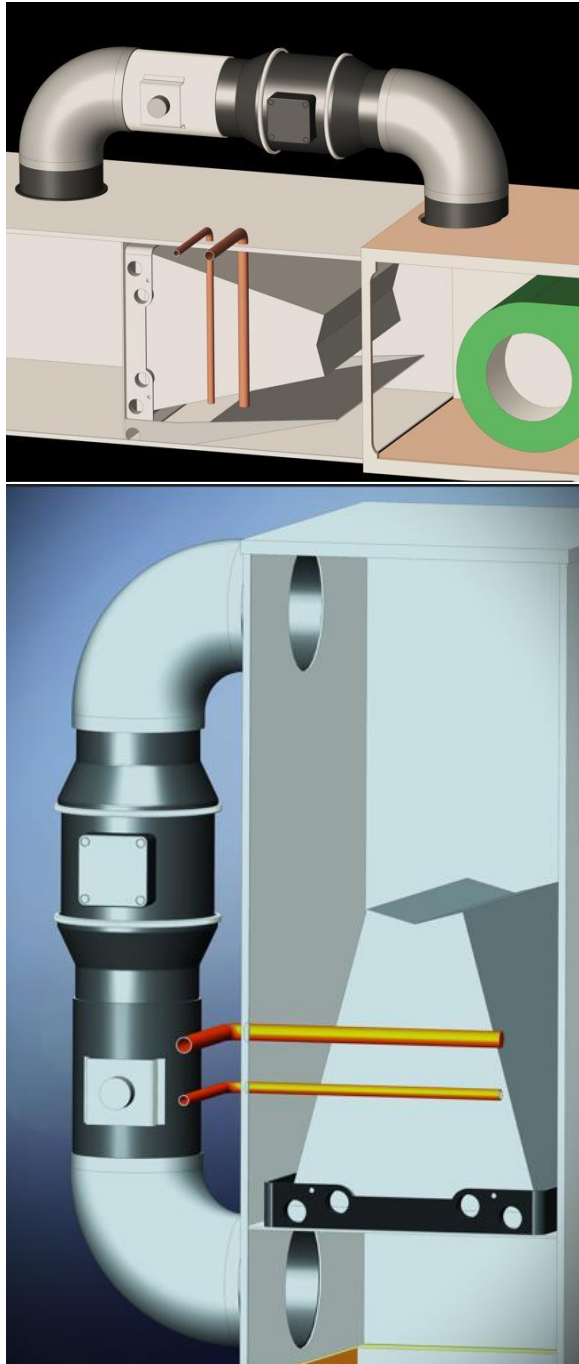

The bypass fan is installed in series with the optional motorized damper. The maximum duct length for the bypass fan, including up to two 90-degree elbows, is 25 feet. For longer duct runs, consult the manufacturer.

The motorized damper can be installed anywhere within the fan's duct run, but it is preferably located on the fan's intake (suction) side. Ductwork can be rectangular but must have a cross-sectional area equivalent to the fan's diameter. A qualified installer must perform the ductwork installation, ensuring compliance with all applicable local codes and regulations.

The accompanying figures illustrate the bypass fan and damper installed in series with the supply or return duct of an air handling unit. The bypass fan is also shown installed parallel to the evaporator coil. In this parallel configuration, the fan draws air from the coil's intake, discharges it, and then the combined airflow is introduced into the coil's outlet.



System configuration can be set through the installer GUI into 3 application modes.

Total Comfort Mode (TCM)

Total Comfort Mode prioritizes cooling comfort by enhancing dehumidification. It achieves this by lowering the indoor coil's leaving air dew point, which results in reducing the effect of sensible cooling and elongating each cooling cycle. This results in drier cooler air, immediate dehumidification and significantly less cycling.

TCM employs an adaptive algorithm:

1. If dehumidification is needed, the system maximizes dehumidification.
2. When sensible cooling is required, the system gradually shifts to meet the sensible cooling load.

TCM is compatible with various condenser types, including:

- Single stage
- Dual stage
- Heat pump
- Inverter-type heat pumps

TCM applications span a wide range of applications:

- Residential
- Commercial
- Institutional
- Industrial

Maximum Dehumidifier Mode (MDM) :

Maximum Dehumidifier Mode requires an Independent Air Conditioner system as a standalone system. The controller is designed to allow any HVAC contractor to create a custom dehumidifier using readily available, cost-effective air conditioning components.

5 19 Vesna
Bowmanville On.
Canada
L1C 0C7

2981 Ford ST.
Ogdensburg, New York
USA
13669



MDM prioritizes dehumidification. It enhances dehumidification by lowering the coil's supply air dew point, which reduces sensible cooling and extends the cooling cycle, resulting in drier air. The system's logic and algorithm are designed to maximize dehumidification capacity.

MDM is compatible *only* with single-stage condenser units and can be configured as a standalone system or ducted in parallel with multiple AC systems.

+

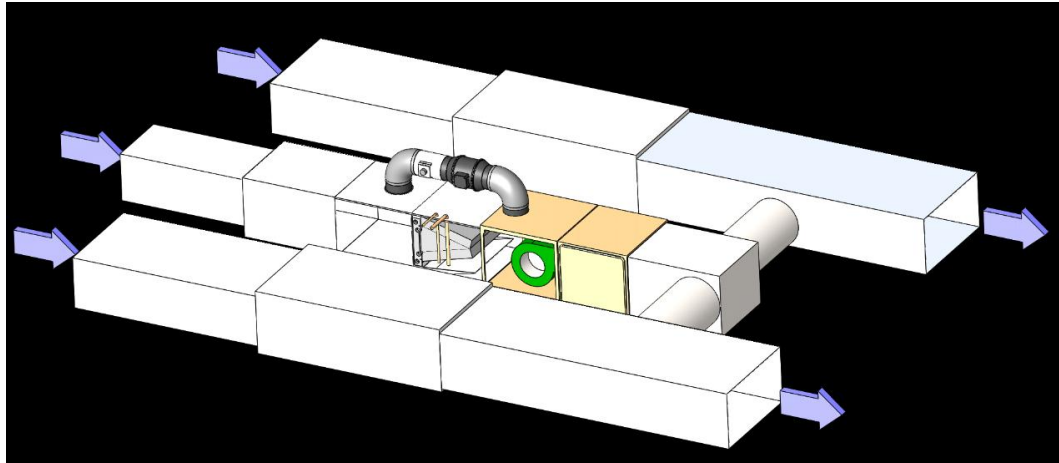

The application can vary from:

- Residential
- Commercial
- Institutional
- Industrial

Adaptable Maximum Dehumidifier Mode (AMDM) : The IABS is combined as a stand-alone system. The stand-alone unit is integrated into the delivery air of a central unit.

Same as the MDM, **except:**

Also, it functions as a standalone unit but is integrated into the air supply duct of a central HVAC system. Like the Maximum Dehumidifier Mode (MDM), the IABS prioritizes dehumidification. It can be installed within the supply air duct of *any* central HVAC system (as illustrated in the accompanying diagram).

- It can be ducted in parallel with the central air system (as shown in the drawing).

6 19 Vesna
Bowmanville On.
Canada
L1C 0C7

2981 Ford ST.
Ogdensburg, New York
USA
13669



- The indoor unit must be capable of switching between low and high blower speeds. A single-stage indoor unit must be matched with a single-stage condenser to facilitate fan control.
- The high blower speed must be at least 450 CFM per ton, while the low blower speed should be approximately 350 CFM per ton.

+

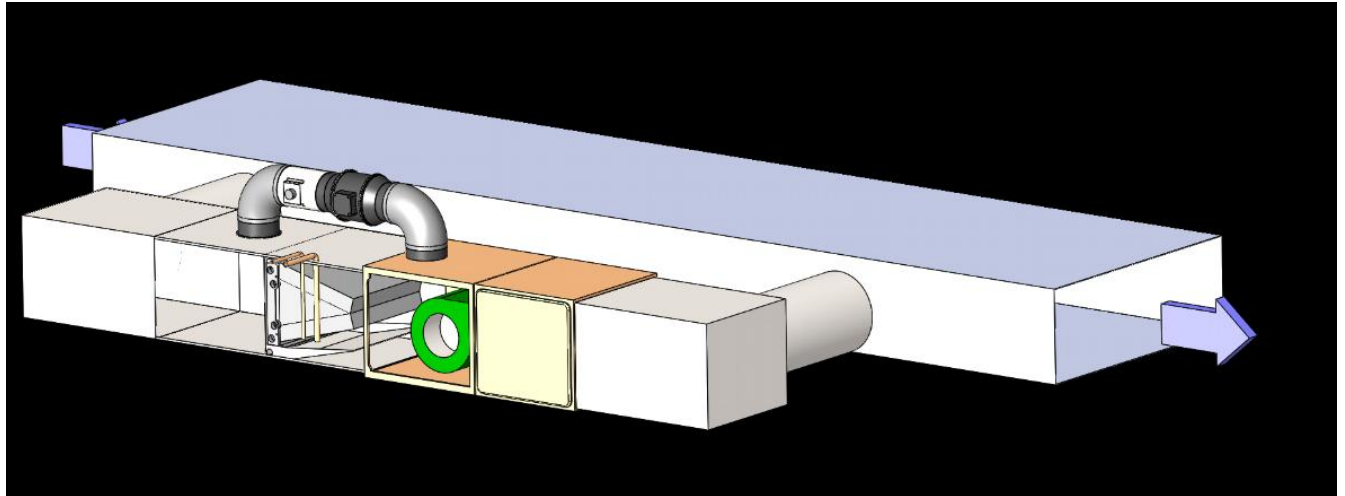

7 19 Vesna
Bowmanville On.
Canada
L1C 0C7

2981 Ford ST.
Ogdensburg, New York
USA
13669



8 19 Vesna
Bowmanville On.
Canada
L1C 0C7

2981 Ford ST.
Ogdensburg, New York
USA
13669

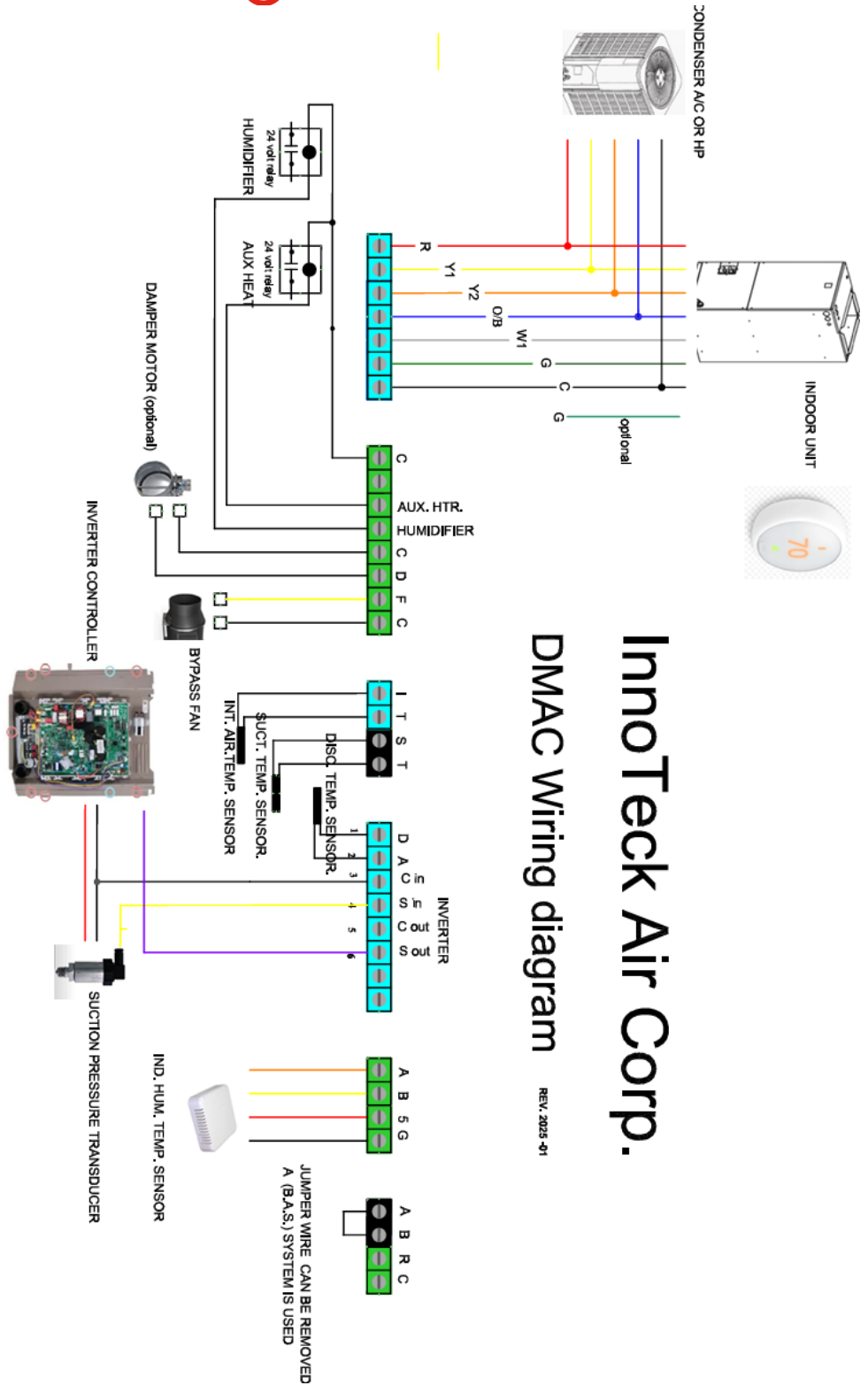

InnoTek Air Corp.

DMAC Wiring diagram

REV. 2025 -01



The wiring diagram's left side details connections between the indoor unit and the DMAC controller via a BLUE terminal connector. Select the appropriate terminal based on the system type: single-stage, dual-stage, or heat pump.

The system supports a humidifier and auxiliary heat (as a second stage). It also offers the option to control either a second dehumidifier (e.g., for a basement) or an Inverter Bypass relay. The Inverter Bypass is specifically for systems using an inverter compressor outdoor unit.

The DMAC operates on a low-voltage 24 VAC (maximum 0.5 amps) and is powered by the indoor unit's transformer.

The damper connects to the green D and C terminals. The fan connects to the F and C terminals through a fan terminal box. Maintain correct polarity by matching wire colors.

The sensor terminals are labeled I/T (Intake Air Temperature) and S/T (Suction Temperature).

The diagram's right-side features additional green terminals for connecting an inverter heat pump. If your system uses an inverter heat pump, consult the manufacturer's documentation *before* purchasing.

Terminals A and B can be optionally connected to a Building Automation System (BAS) connectivity. If a BAS is not used, a jumper wire must be installed.

5) USER (GUI) GRAPHICAL USER INTERFACE DISPLAY

10 19 Vesna
Bowmanville On.
Canada
L1C 0C7

2981 Ford ST.
Ogdensburg, New York
USA
13669



BYPASS FAN OFF
Dew Point: 9.3 °C

25 °C 37 % RH
Mode AUTO Setting 34 %RH



BYPASS FAN OFF
Dew Point: 9.3 °C

25 °C 37 % RH
Mode AUTO Setting 34 %RH
INNOTEK AIR TCM
20250120-52 R D IP:192.168.2.57

The display's top section indicates the bypass fan's status (on or off) and its current speed (as a percentage).

The center of the display shows the current temperature and relative humidity (RH). Touching the mode control toggles the dehumidification mode between on, off, and auto.

The "on" mode is recommended for off-peak seasons or when addressing existing mold issues. The "auto" mode is ideal for peak seasons.

The bottom of the display (labeled TCM) indicates the current system set up mode.

New Dew Point feature.

BYPASS FAN OFF
RH: 37.0 %

25 °C DP: 9.3 °C
Mode AUTO DP Setting 8 °C



11 19 Vesna
Bowmanville On.
Canada
L1C 0C7

2981 Ford ST.
Ogdensburg, New York
USA
13669



Touching the settings option displays a menu with a check mark, up and down arrows, and an "X." Use the up and down arrows to adjust the setpoint. Press the check mark to confirm the change, or the "X" to cancel and return to the previous setting.

A new Dew Point feature provides enhanced control, allowing you to switch between Relative Humidity (RH) and Dew Point control. Simply touching the displayed RH value toggles the system to Dew Point control. This feature improves comfort management, particularly for mold prevention, and is highly beneficial when used with a programmable thermostat. It is also ideal for laboratory environments.

6) INSTALLER GUI

To access the installer GUI, press and hold the logo for at least 5 seconds.



Once in the installer GUI, the left and right arrows navigate through four alternate pages. Pressing the up arrow returns the display to its normal operating mode.

The alternate pages are;

CONFIGURATION

BYPASS FAN CONTROL

SETTINGS

TCM CONTROL SETTINGS

12 19 Vesna
Bowmanville On.
Canada
L1C 0C7

2981 Ford ST.
Ogdensburg, New York
USA
13669



SENSOR CALIBRATION

HISTORY

SAFETY

THERMOSTAT STATUS

RELAY STATUS

SYSTEM STATE

TIMMING

Configuration enables the installer to choose between models, types of systems, and others.

CONFIGURATION



Model: TCM

System: A/C

Stages: Inverter

Thermostat control: Single

Bypass: On

Aux mode: 2nd Dehumidifier

The **SETTINGS** menu allows adjustment of setpoints, maximum fan speed, controller sensitivity, and access to a Test mode.

SETTINGS



Suct. Temp. SP: 42.0 °F

Delivery Air Temp. SP: 42.0 °F

RH sensitivity: 1.5 %

Max fan speed: 90 %

Test mode: OFF



SENSOR CALIBRATION allows for the calibration of all sensors.

SAFETY provides access to various safety settings.

The HISTORY, RELAY STATUS, THERMOSTAT STATUS, and SYSTEM STATUS options provide diagnostic tools for installers.

In any given menu, when prompting a function, a? appears, and pressing on it will guide the installer with information on what to do

7) Connecting to WiFi and Accessing the System:

- A. Locate the IP Address:** Tap on the IP address displayed at the bottom of the screen.
- B. Enter Credentials:** You will be prompted to enter a Wi-Fi connection name (SSID) and password.

If the displayed IP address is incorrect unchanged (127.0.0.1) or unresponsive, power cycle the device: turn it off, wait 5 seconds, and then turn it back on.
- C. Download TigerVNC:** On your local computer, download and install the TigerVNC application from: <https://tigervnc.org/>
- D. Connect via TigerVNC:** Open TigerVNC and enter the following credentials:
 - a. Username:** innotek (lowercase)
 - b. Password:** DMAC (uppercase)
- E. App Connection:** For connecting via the dedicated mobile application, please refer to the detailed instructions provided in the application's documentation.



F. Mode Reset: After any system parameter or configuration changes, power cycle the device by switching the mode to "off" for 5 seconds.

Appendix 1 (10Kohm sensor)

USP10982 (RESISTANCE VS. TEMPERATURE TABLE)

Temp (°C)	Temp (°F)	Resistance Ratio Rt/R@+25°C	TC (%/°C)	Resistance Ω
-5	23.0	4.232700	-5.28	42,327.00
-4	24.8	4.015900	-5.24	40,159.00
-3	26.6	3.811500	-5.21	38,115.00
-2	28.4	3.618700	-5.18	36,187.00
-1	30.2	3.436800	-5.15	34,368.00
0	32.0	3.265000	-5.11	32,650.00
1	33.8	3.102900	-5.08	31,029.00
2	35.6	2.949800	-5.05	29,498.00
3	37.4	2.805200	-5.01	28,052.00
4	39.2	2.668500	-4.98	26,685.00
5	41.0	2.539200	-4.95	25,392.00
6	42.8	2.417000	-4.92	24,170.00
7	44.6	2.301300	-4.89	23,013.00



8	46.4	2.191800	-4.86	21,918.00
9	48.2	2.088200	-4.83	20,882.00
10	50.0	1.990100	-4.80	19,901.00
11	51.8	1.897100	-4.77	18,971.00
12	53.6	1.809000	-4.74	18,090.00
13	55.4	1.725500	-4.71	17,255.00
14	57.2	1.646300	-4.69	16,463.00
15	59.0	1.571200	-4.66	15,712.00
16	60.8	1.499900	-4.63	14,999.00
17	62.6	1.432300	-4.60	14,323.00
18	64.4	1.368100	-4.57	13,681.00
19	66.2	1.307200	-4.54	13,072.00
20	68.0	1.249300	-4.52	12,493.00
21	69.8	1.194200	-4.50	11,942.00
22	71.6	1.141900	-4.47	11,419.00
23	73.4	1.092200	-4.44	10,922.00
24	75.2	1.045000	-4.41	10,450.00
25	77.0	1.000000	-4.39	10,000.00
26	78.8	0.957200	-4.36	9,572.00
27	80.6	0.916500	-4.34	9,165.00
28	82.4	0.877700	-4.31	8,777.00
29	84.2	0.840800	-4.28	8,408.00
30	86.0	0.805700	-4.26	8,057.00
31	87.8	0.772200	-4.24	7,722.00
32	89.6	0.740200	-4.22	7,402.00
33	91.4	0.709800	-4.18	7,098.00
34	93.2	0.680800	-4.16	6,808.00
35	95.0	0.653100	-4.14	6,531.00
36	96.8	0.626700	-4.12	6,267.00
37	98.6	0.601500	-4.09	6,015.00
38	100.4	0.577500	-4.07	5,775.00
39	102.2	0.554500	-4.05	5,545.00
40	104.0	0.532600	-4.02	5,326.00
41	105.8	0.511700	-4.00	5,117.00
42	107.6	0.491700	-3.99	4,917.00
43	109.4	0.472500	-3.96	4,725.00
44	111.2	0.454300	-3.93	4,543.00
45	113.0	0.436800	-3.91	4,368.00
46	114.8	0.420100	-3.89	4,201.00
47	116.6	0.404100	-3.87	4,041.00
48	118.4	0.388800	-3.85	3,888.00
49	120.2	0.374200	-3.82	3,742.00
50	122.0	0.360200	-3.80	3,602.00
51	123.8	0.346800	-3.78	3,468.00
52	125.6	0.334000	-3.76	3,340.00
53	127.4	0.321700	-3.75	3,217.00
54	129.2	0.309900	-3.73	3,099.00
55	131.0	0.298600	-3.70	2,986.00
56	132.8	0.287800	-3.68	2,878.00
57	134.6	0.277400	-3.66	2,774.00
58	136.4	0.267500	-3.64	2,675.00
59	138.2	0.257900	-3.63	2,579.00
60	140.0	0.248800	-3.60	2,488.00
61	141.8	0.240000	-3.58	2,400.00
62	143.6	0.231600	-3.56	2,316.00
63	145.4	0.223500	-3.56	2,235.00
64	147.2	0.215700	-3.52	2,157.00
65	149.0	0.208300	-3.50	2,083.00
66	150.8	0.201100	-3.51	2,011.00
67	152.6	0.194200	-3.48	1,942.00
68	154.4	0.187600	-3.44	1,876.00

16 19 Vesna
Bowmanville On.
Canada
L1C 0C7

2981 Ford ST.
Ogdensburg, New York
USA
13669



Appendix 2 Performance

Within + or – 10 percent depending on equipment selection and type and TXV superheat adjustment and suction line set point.

Humidiflex System Performance					
Temp	Degree F	75	75	80	80
Humidity	RH	50%	60%	50%	60%
Water	lbs/hr.	3.5	4.6	4.6	5.5
Removal	PPD pints	80	105	105	127
Sens. cool cap.	BTU/hr	7200	7500	7900	7200

capacitv per ton PPD pints per dav

Appendix 3 Specification and sizing

The same table for any model

InnoTek Air Humidiflex System specification				
MODEL	CONNECTION SIZE	PHYSICAL FAN SIZE	NOISE	POWER
IAHS-8	8" Dia	8.5" * 11.9" * 9.2"	39 DBA	110 WATTS
IAHS-10	10" Dia	10.2" * 11.9" * 12.2"	42 DBA	250 WATTS
IAHS-12	12" Dia	12.2" * 17.7" * 14"	62 DBA	250 WATTS



Humidiflex System Sizing

MODEL	< 400 CFM / Ton		> 400 CFM / Ton	
	CFM	SIZE tons	CFM	SIZE tons
IAHS 8	< 400	1.5 - 2.5	> 400	1.5 - 2.0
IAHS 10	< 400	3.0 - 4.0	> 400	2.5 - 3.0
IAHS 12	< 400	4.0-7.5	> 400	3.5 - 5

Note; Size of a IAHS for a unit having a tonage of SIZE tons, for air below, or above 400 CFM per ton.

18 19 Vesna
Bowmanville On.
Canada
L1C 0C7

2981 Ford ST.
Ogdensburg, New York
USA
13669